

O. LOUDNESS CIRCUIT TEST

1. Connect Audio Oscillator to both channel AUX input jacks. Adjust level for 21.9V output into the 8 ohm load. Adjust unit VOLUME control (from MAXIMUM) for a 30dB reduction in output level.
2. With oscillator frequency at 100Hz, compare output level with LOUDNESS switch IN and OUT. Verify a 7dB \pm 2dB boost with switch IN.
3. Change oscillator frequency to 10KHz. Verify a 7dB \pm 2dB boost in output voltage when LOUDNESS switch is depressed.

ADJUSTMENT PROCEDURE

A. TEST EQUIPMENT

Refer to Table 1 for recommended test equipment.

B. PRELIMINARY PROCEDURES

The preliminary procedures outlined in the Performance Verification section of this manual are applicable in their entirety.

C. UNIT DISASSEMBLY

Remove the top cover. (See Service Notes section for disassembly instructions).

D. BIAS ADJUST

1. Turn Line Switch to OFF. Rotate the bias adjust potentiometers R523 and R524 fully C.W. (See Figure 14 for component locations).

2. Switch the Wattmeter IN and set the Variac to 0.

3. Turn the Line Switch ON and slowly advance the Variac to 120 VAC while observing the Wattmeter. The Wattmeter should indicate less than 35W at 120V. If the Wattmeter indicates either 0 or greater than 35W, a defect exists. Turn off the unit and correct the fault.

4. Reduce the unit VOLUME to minimum. Connect a low-range voltmeter across series combination of R553 and R549 (voltmeter in 0-100mV range). See Figure 14 for component and connection point location.

5. Adjust R523 for voltmeter reading between 11 and 18mV.

6. Change location of voltmeter to series combination of R550 and R554. See Figure 14.

7. Adjust R524 for voltmeter reading between 11 and 18mV.

Note: 11mV drop across the series resistance represents 30mA idling current in the output stage. 18mV represents 50mA idling current.

E. DC BALANCE ADJUST

1. Monitor the left channel output with a VTVM in the DC mode.
2. With the unit VOLUME control set to minimum, adjust the left channel Zero Set potentiometer R517 for a DC output voltage of 0V \pm 50mV. (See Figure 14 for component location).
3. While monitoring the right channel output, adjust the right channel Zero Set potentiometer R518 for a DC output voltage of 0V \pm 50mV.

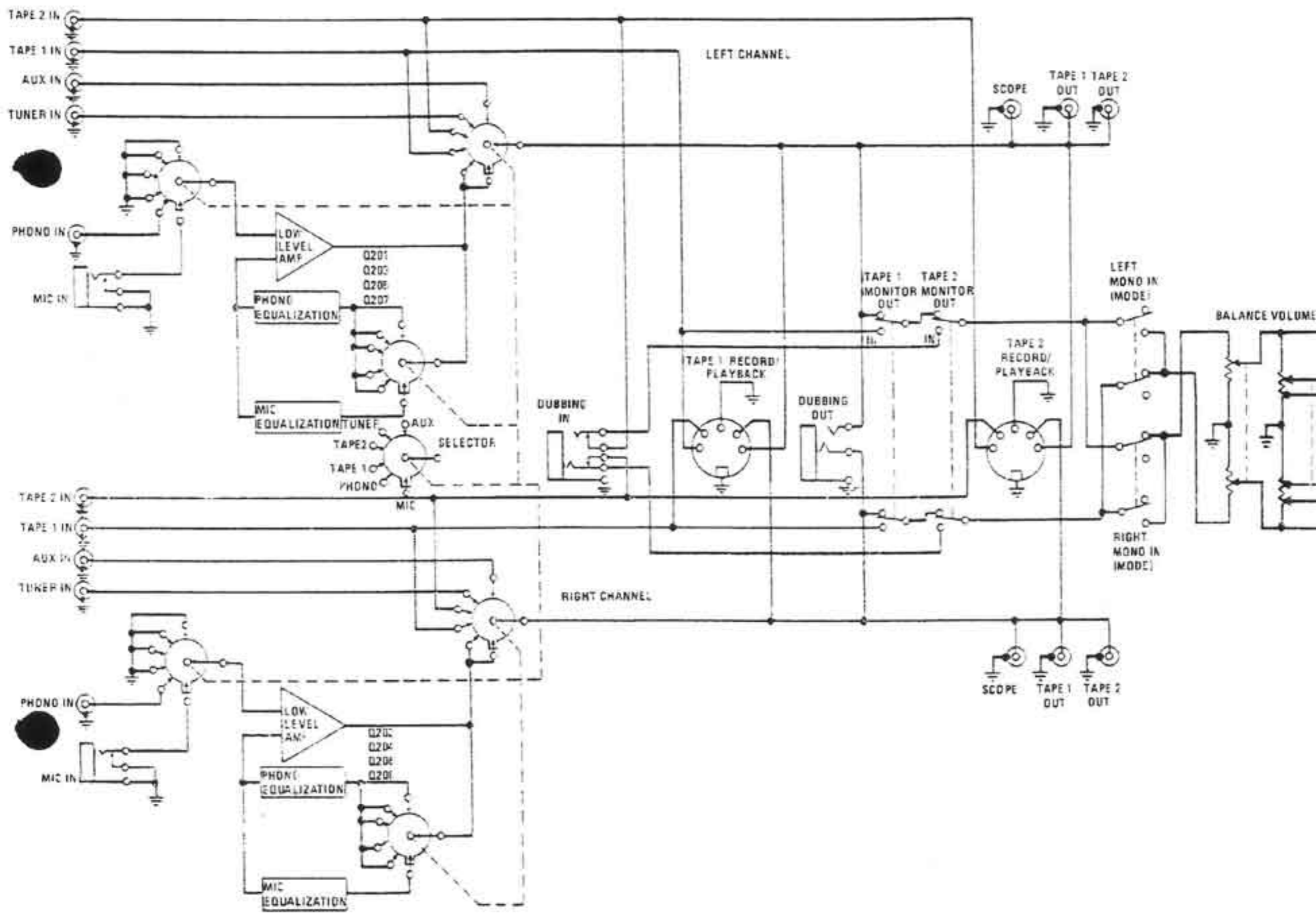
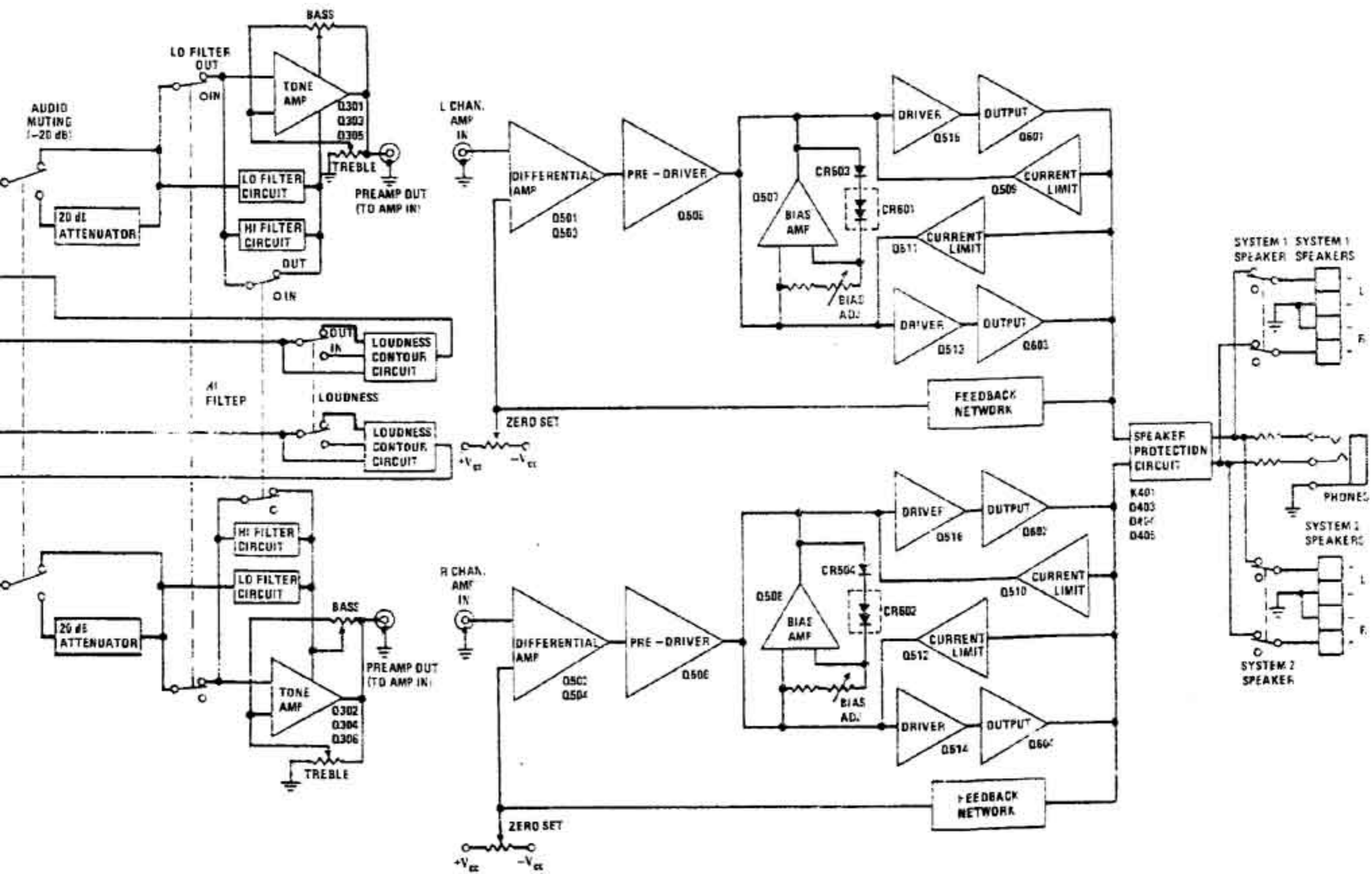
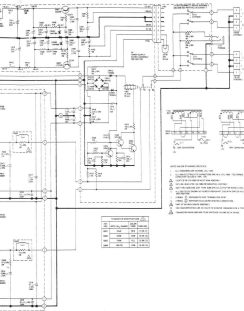

Figure 8. Functional Block Diagram





- NOTES ON THE WIRING DIAGRAM:**
1. ALL CONNECTIONS SHOULD BE MADE TO THE BATTERY POSITIVE (+) TERMINAL.
 2. ALL CONNECTIONS SHOULD BE MADE TO THE BATTERY NEGATIVE (-) TERMINAL.
 3. ALL CONNECTIONS SHOULD BE MADE TO THE BATTERY POSITIVE (+) TERMINAL.
 4. ALL CONNECTIONS SHOULD BE MADE TO THE BATTERY NEGATIVE (-) TERMINAL.
 5. ALL CONNECTIONS SHOULD BE MADE TO THE BATTERY POSITIVE (+) TERMINAL.
 6. ALL CONNECTIONS SHOULD BE MADE TO THE BATTERY NEGATIVE (-) TERMINAL.
 7. ALL CONNECTIONS SHOULD BE MADE TO THE BATTERY POSITIVE (+) TERMINAL.
 8. ALL CONNECTIONS SHOULD BE MADE TO THE BATTERY NEGATIVE (-) TERMINAL.
 9. ALL CONNECTIONS SHOULD BE MADE TO THE BATTERY POSITIVE (+) TERMINAL.
 10. ALL CONNECTIONS SHOULD BE MADE TO THE BATTERY NEGATIVE (-) TERMINAL.

FUSE NO.	RATING	PROTECTED CIRCUIT
15	15A	IGNITION SWITCH
20	20A	HEADLIGHTS
25	25A	TAILLIGHTS
30	30A	HORN
40	40A	FUEL PUMP
50	50A	WATER PUMP
60	60A	ALTERNATOR
75	75A	ENGINE
100	100A	BATTERY

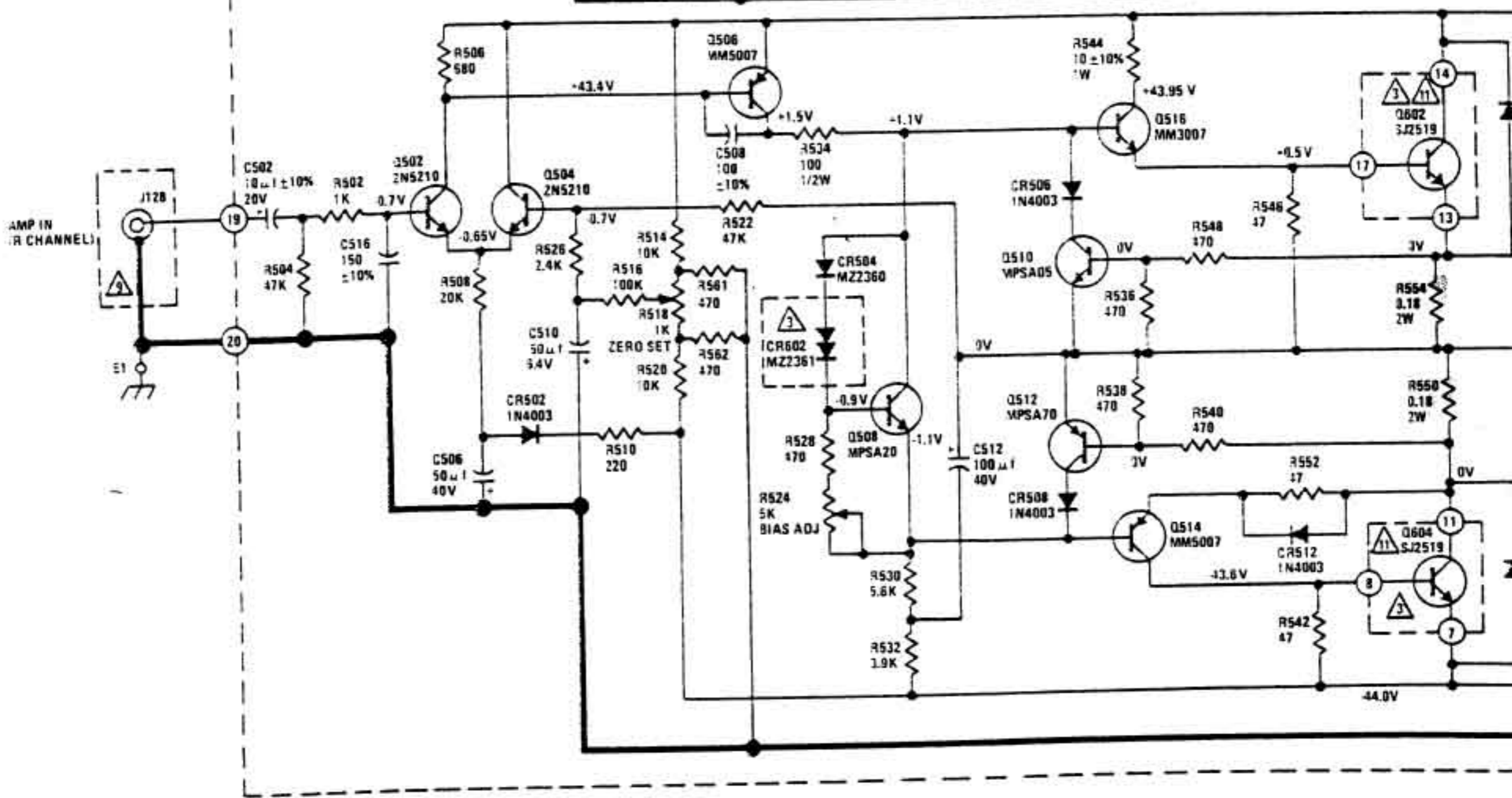
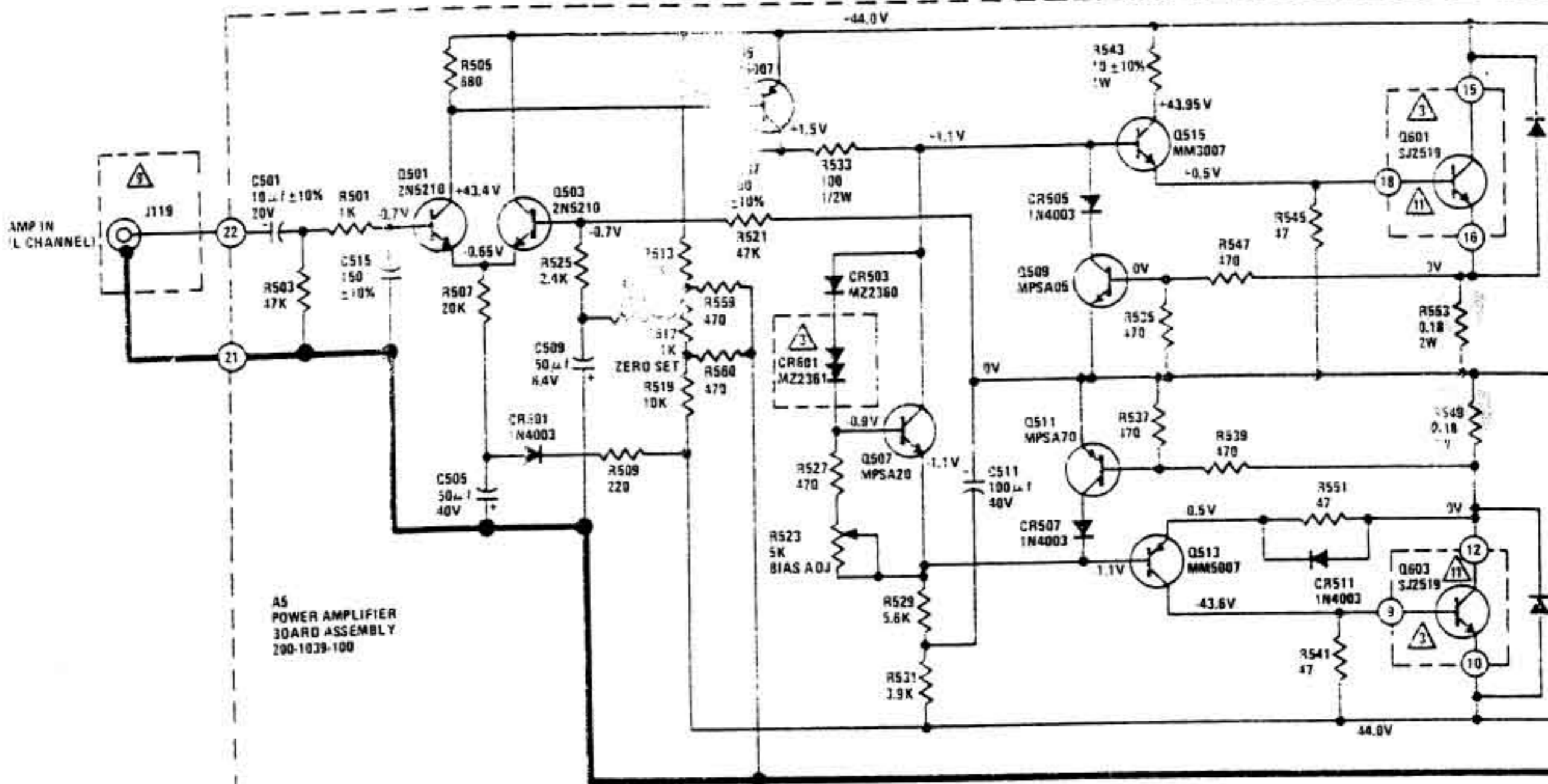
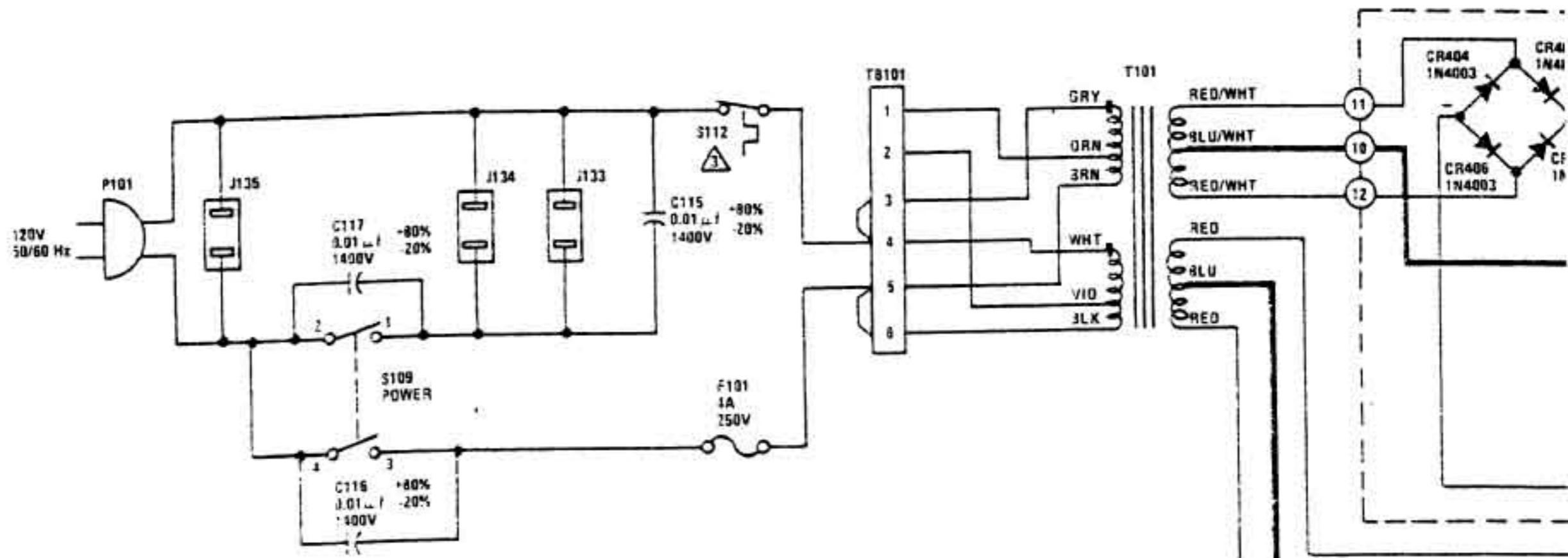

Figure 7B. Model 1120 Schematic

A6 JACK BOARD ASSEMBLY
200-1038-100
I PLUS JACK INPUT CKT BD 125-1056-000

1/2 A2 PHONO/SELECT
BOARD ASSY
200-1043-100

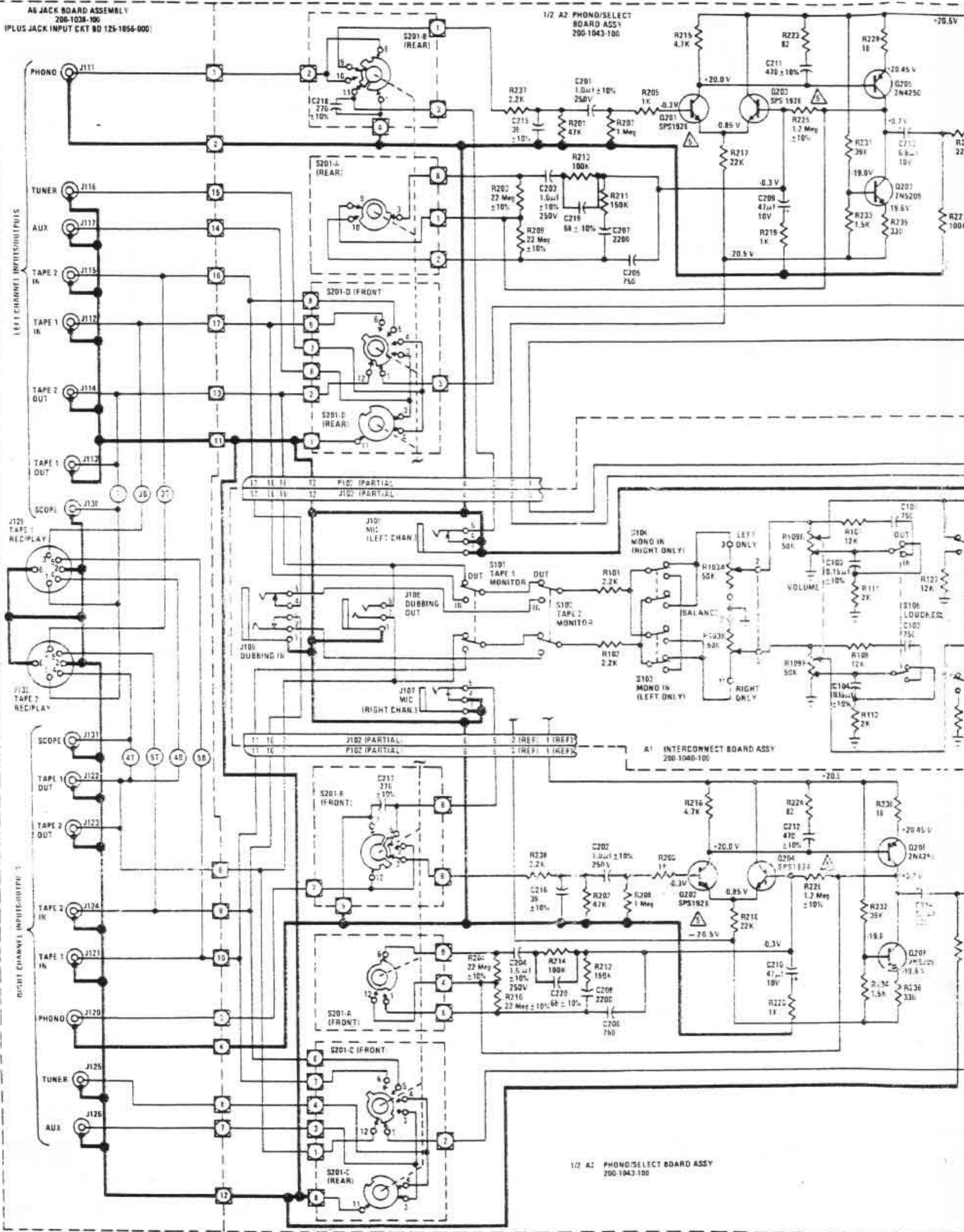
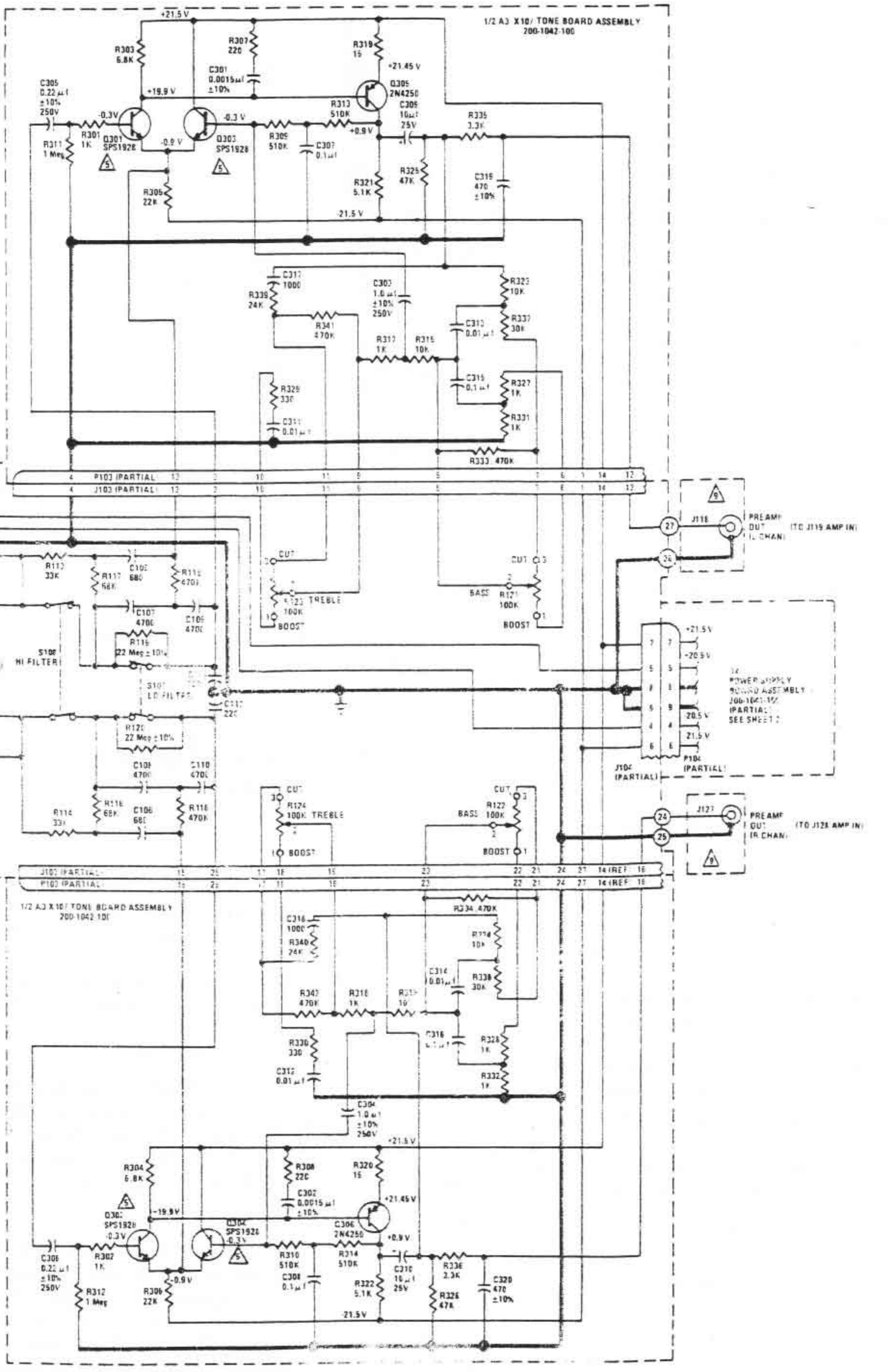

Figure 7A. Model 1120 Schematic

1/2 A3 X10/ TONE BOARD ASSEMBLY
200-1042-100



PREAMP
OUT
(L CHAN)
(TO J118 AMP IN)

PREAMP
OUT
(R CHAN)
(TO J127 AMP IN)

14
POWER SUPPLY
BOARD ASSEMBLY
200-1042-100
PARTIAL
SEE SHEET 1

1/2 A3 X10/ TONE BOARD ASSEMBLY
200-1042-100